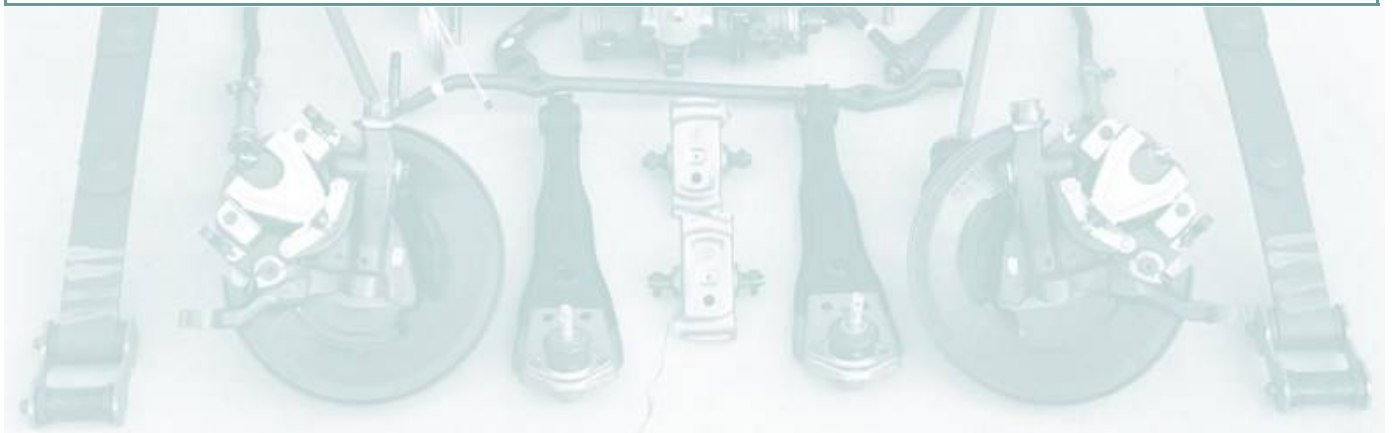

Table of Contents

(Arranged Alphabetically)

Common Name	Basic Ford Part Number	Page
Control Arms—Lower	3078	3
Control Arms—Upper	3082	11
Cross Members	5026	17
Idler Arms	3350, 3351 and 3352	18
Spring Perches	3388	21
Steering Boxes	3504	26
Strut Rods	3468	30
Tie Rods	3A130 and 3A131	34



Lower Control Arms

(Arm Assembly—Front Suspension Lower)

From 1965 to 1973 there is several versions of lower control arms that Ford used. This section here will highlight the differences on original assembly line pieces, show unique features, and help to identify what is correct for each year. Within these years there is two basic styles of lower control arms. The “early” style used in 1965 and 1966 is a smaller control arm. Then in 1967 there is a design change to a larger control arm used till 1973. Difference shown in the following pages.

1965 and 1966: C4DZ-3078-A

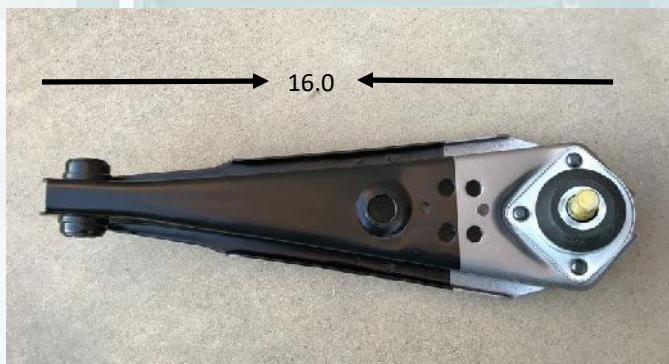

Control arms that were used in 1965 and 1966 are shorter in length (16 inches) than those in later years making it the easiest way to recognize them. All lower control arms were dipped in black paint. The amount and pattern in which the control arms were dipped can vary but generally about 3/4 of the control arm is dipped leaving the rest of the arm an exposed bare metal.

Version A



Version B



Jacking Tabs All lower control arms during these years had jacking tabs spot welded to the base of the control arm as shown here. It seems that the square version (Version A), came on earlier cars during the 1965 model year and into the 1966 model year and then eventually changed to a more rounded version (Version B) in the 1966 model year. However, there is no exact date on when this transition happened.



Side by side comparison

65/66 Lower Control Arms cont.



Ball Joint Boots Assembly line original lower control arms during these years had three different versions of boots that were used. The first version had the word LOWER and the engineering number C20A-3A105-A molded in the boot. The second and most common version boot, will simply just have the word LOWER molded in the boot and no engineering numbers. The third version boot has the engineering number C50A-3A105-A molded into the rubber as well as the word LOWER. These boots were eventually replaced by a C70A boot so they are an extremely rare find today in any useable condition.



Rivets Lower control arms during these years had dome style rivets that were used on original assembly line units. Pictures here show the view from the top side, and also from the bottom side. Later service replacements sold after 1966 would typically have waffle pattern stamped rivets.

Zerk Fitting Plug All vehicles that left the factory had a plug installed. These would later be replaced by a zerk fitting when serviced to add grease in to the ball joint.



Stampings Some, but not all, control arms had stampings that resemble date codes on them. Pictures here show samples of some of these stampings that would typically be found on the side and in the bare metal end of the control arm.



Ball Joint Boot Retainer Two versions of retainers were used for the ball joints in 65 and 66. Version A is a flat piece of stamped metal with flat edges seen on earlier cars. Version B has raised edges and is also the most common that is seen on survivor cars and was then used on all later years until end of 1973 production.

Ball joint Early original ball joint studs in 65 will have a slot in them. This design eventually went away to the more common seen without this (see comparison above). Yellow paint is typically on the ends in varying amounts.

1967: C70Z-3078-B



For the 1967 Mustang the design changed as the control arms became a little longer to an overall length of 18.5 inches. These control arms, just like all other years, were dipped in black paint about 3/4 of the way to leave the ends where the ball joint is a bare metal finish. The 1967 control arms are a one year only design, and will not interchange with any other years.



Jacking Tabs Original control arms still have a spot welded jacking tab like previous years, with this version being used in almost all cases.



Zerk Fitting Plug All control arms from the factory already came with grease installed, and plugs. Zerk fittings were later installed when the vehicle was serviced.



Ball joint boot retainer Control arms in 1967 all have the same style boot retainer as the flat style is no longer used in production anymore.

1967 Lower Control Arms cont.



Ball Joint Boots Assembly line control arms used two versions of boots in 1967. Although not very often, some of the earlier control arms actually had the C50A-3A105-A boots carried over from previous years. These eventually were replaced as the C70A-3A105-A boot became the most common boot used.

Paint The ball joint stud will typically have some yellow paint on them from the factory that is visible when the car is assembled. The amount of paint varies.



Rivets As in previous years, the factory original lower control arms used the same style of rivet as seen here. This would be a dome shaped rivet head on the top side and the flat part of the rivet on the bottom. The finish of these rivets was always a natural finish in a darker grey color.

Sway bar washer Starting in 1967 a washer was pressed to the bottom of the control arm for the sway bar end links. Previous years did not have this.



Stampings Some, but not all, control arms had stampings that may resemble date codes on them. Pictures here show samples of some of these stampings that would typically be found on the side and in the bare metal end of the control arm.

1967: C7WY-3078-B Cougar Specific



C7WY-3078-B As a special note, and difference, to the Mustang lower control arms, there was an almost identical lower control arm use on the new 1967 Mercury Cougar that year. They are identical in every way, however not interchangeable because the holes for the strut rods are slightly different making the holes wider apart. Hard to spot when looking at the control arms by themselves but much easier to spot when laying them side by side as shown below.

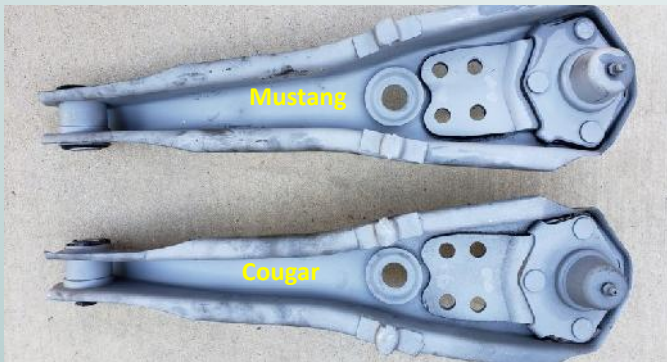

Mustang Shown here the approximate center to center dimensions of the strut rod mounting holes in the control arm are 1.30 inches.



Cougar Shown here the approximate center to center dimensions of the strut rod mounting holes in the control arm are 1.60 inches.

1968 and 1969: C8GY-3078-A



The design for the lower control arms changed again for the 1968 and 1969 model year as shown here. The most noticeable difference now when compared to previous years is two holes for the strut rods instead of four. Same length as the 1967 control arms, plus Mustang and Cougars now also share the same lower control arm design going forward.



Ball Joint Boots For 1968 and 1969 version lower control arms, shown here, the same boot is used now which is molded with the C70A-3A105-A engineering number.



Rivets 1968 Most original lower control arms in 1968 have the domed style rivets in place. This continued thru most of the production year and then changed to the waffle style.



Rivets 1969 Starting in late 1968 and going thru the 1969 model year, original lower control arms now all have the waffle style rivets being used and no longer the domed style.



Jacking tabs Shown here the most common style of jacking tabs on the lower control arms during these years. All control arms had jacking tabs.



Sway Bar Washer As with the previous model year of 1967 the C8GY-3078-A lower control arm has a pressed washer in place that works with the sway bar end links. This works well with the sway bar. Some service replacements and reproductions are missing this washer completely.



1970: D00Z-3078-A



The 1970 lower control arms changed once again for Mustangs and Cougars and also became a one year only design. Biggest noticeable difference is the washer that is pressed to the control arm as shown below. The control arms are dipped in black paint and Ford drawings indicate this should be dipped in the range of 11 to 13 inches from the bottom.



Ball Joint Boots In 1970 we see the continued use same of the ball joint boot which is marked with the C70A-3A105-A engineering number.



Rivets The waffle style rivets are continued to be used in 1970. The "waffle pattern" comes from the pressing of the rivets in place.



Zerk fitting plug The zerk plug was on all lower control arms after they were filled with grease at the factory. Note these are now red which started in about 1968 model year.



Jacking tabs Shown here the most common style of jacking tabs on the lower control arms during these years. All control arms in 1970 had jacking tabs.



Sway Bar Washer The special washer that is used on the lower control arm for the sway bar end links is changed again in 1970. Note the differences from the previous years in this style of washer with two tabs on the top side that is unique to the D00Z version lower control arms.



1971 to 1973: D10Z-3078-A



The design for the lower control arms changes again with the 1971 model year. Most noticeable changes are that the jacking tabs are no longer welded to the bottom of the arm, but instead there are just raised areas formed in to the lower control arm. In addition the washer for the sway bar end links changes again. All arms are dipped in black paint 3/4 of the way.



Ball Joint Boots The C70A-3A105-A engineering number lower control arm ball joint boots are used during these years on assembly line original units.



Rivets The same style rivets used since 1969 have not changed. There is a waffle pattern on the top side with the ball joint boot retainer as shown above.



Rivets The original style rivets shown here on the bottom side as well as the red zerk plug that all lower control arms had after they were filled with grease from the factory.



Jacking tabs No longer are the jacking tabs spot welded to the lower control arm. Instead there is bumps to replace them located in the same area.



Sway Bar Washer The special washer that is welded to the lower control arm for the sway bar end links is changed again in 1971. Note the differences from the previous years in this style of washer that is unique to the D10Z version lower control arms.



Upper Control Arms

(Arm Assembly—Front Suspension Upper)

Upper control arms used from 1965 to 1973 came in three basic versions with design differences within those. The first version was used during 1965 and 1966 model years and do not interchange with the later years as they are slightly smaller. The second version was then used from 1967 to 1969, and the last version was used from 1970 to 1973. The control arm assembly includes, the control arm itself, the ball joint, the control arm shaft, and the attaching bolts.

1965 and 1966: C4DZ-3082-B

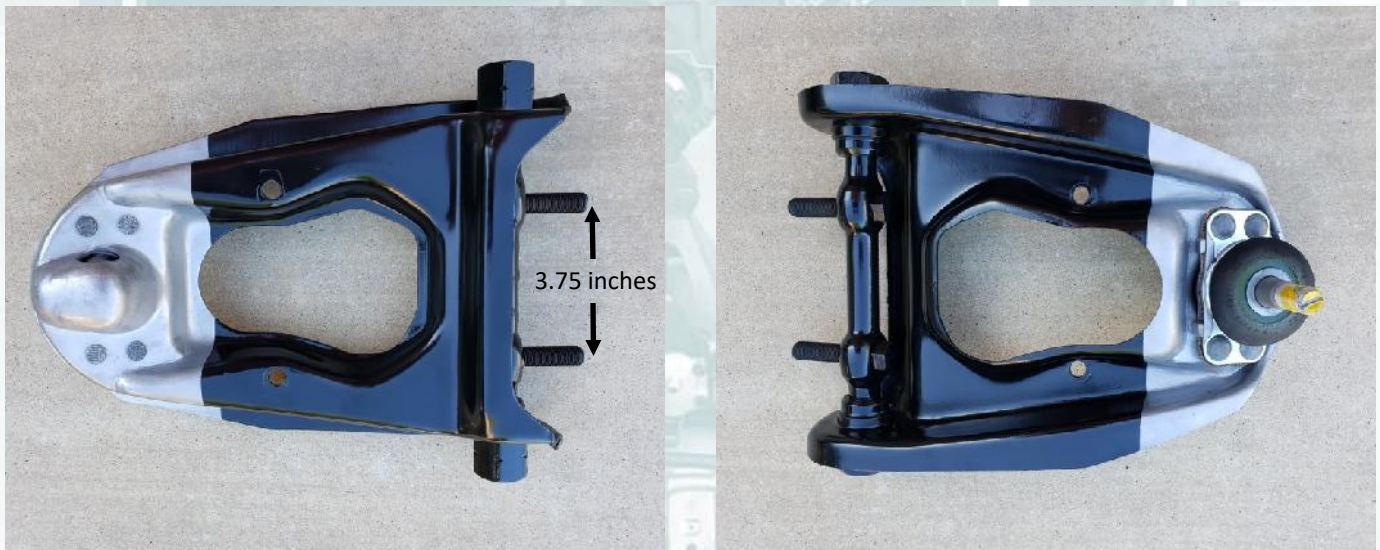

The control arms used during these years, at first glance, look identical to control arms from later years with one key difference. The overall size is smaller. Shown above this measurement is slightly smaller and an easy way to identify what is correct. Other ways to identify these control arms are listed here as well. Note, the paint that was applied to these control arms from the factory generally has them dipped in black paint 1/2 to 3/4 of the way leaving the ball joint area bare metal. Its not uncommon to see the drips and runs from that process of having them dipped.



Ball Joints The ball joints used in 1965 and 1966 were a C2OZ-3049-D part number. The early versions had a slot in the top of the ball joint stud as shown that is no longer seen in later versions. Change over some time in 1965 production. Pictures here show an NOS example which came with bolts, however the correct installation would have rivets, and not nuts and bolts. **Note:** The four flange tabs and overall style which are unique to original Ford ball joints and have not ever duplicated on any reproductions.

65/66 Upper Control Arms cont.



Ball Joint Boots The original ball joint boots used during these years were molded with the engineering numbers of C40A-3A047-A and the word UPPER in them as well. These were then replaced in 1967 with a new design. Since the boots were never serviced by themselves, they are extremely hard to find today in any useable condition.

Control Arm Shaft Two versions of control arm shafts were used during 65/66 under part number C3DZ-3047-A. The first version had caps with no hole so there was no way to add grease. The second (and most common) version then added a drilled and tapped hole where a zerk fitting could be threaded in and used. From the factory these would be already greased, plugged, and with no zerk fitting installed. The attaching studs were a 1/2-20 fine thread –unique to 65/66 control arms.



Rivets The original rivets that were installed on the control arms during these years were compressed creating a waffle pattern as shown here on the top side. The reverse side of the control arm shows the other side of the rivet with correct color.



Stampings Some control arms had stampings that resemble date codes on them although not all stampings fall in a date code format. If present, they are stamped on the front as shown above. Sample stampings shown here as well.

1967 to 1969: C70Z-3082-A, -B, -C

As the cars grew bigger so did some of the suspension components. The upper control arms changed in overall dimensions starting with the 1967 model year versus the previous years. In addition, the upper control arms were no longer dipped in black paint and simply left as bare metal. Variations during these years include what is commonly referred to as a “cutback style” vs a “non-cutback style”. This refers to the ends of the control arm where it was thought necessary to cut them back for clearance. This started about April of 1968 when the Cobra Jet cars were introduced because of the larger tires they were using. The cutback version is the –C version. Ford eventually switched and went back to the non-cutback style during 1969 production because the cutbacks were so prone to cracking. By cutting away the extra material it created a weak area that was stressed and cracks would be common around the edge of the control arm.

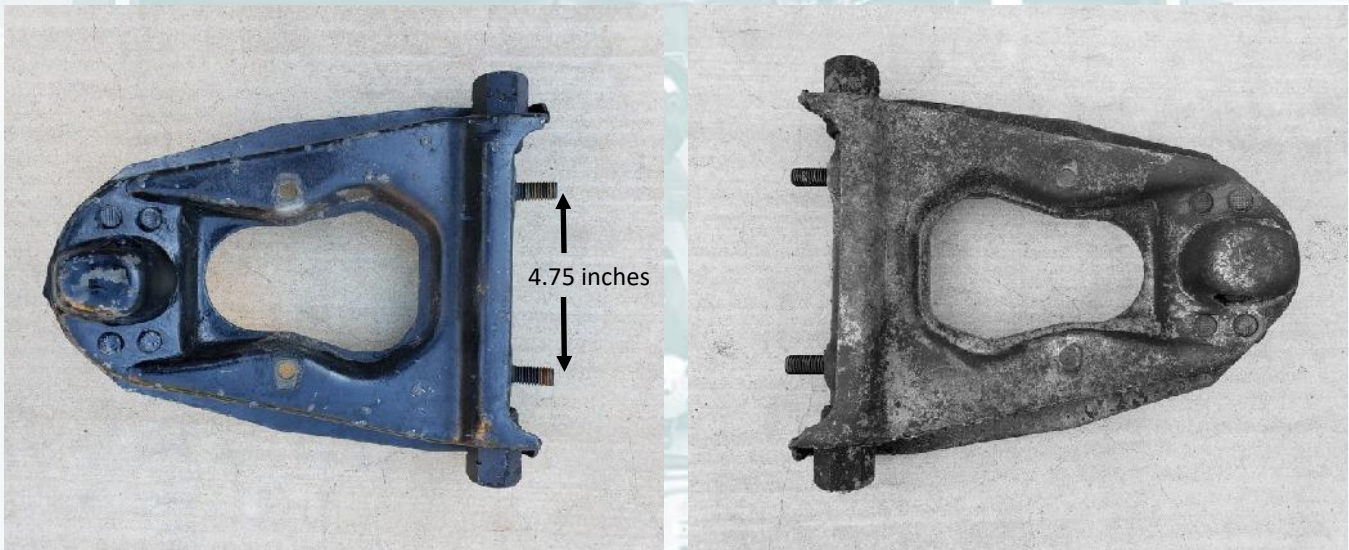

Rivets Four waffle pattern rivets as shown here were used on all original control arms during these years.



Ball Joint Boots Boots used during these years were molded with the engineering number C70A-3A047-A.



Ball Joints The ball joint assemblies that were used from 1967 to 1969 were a part number of C70Z-3049-A. When sold as a service replacement the kits would include nuts and bolts for installation. Rivets were not supplied for installation like the originals. Also note the flange tabs (4 per assembly) that are unique to the original Ford ball joint assemblies.



Control Arm Shaft The control arm shafts used during these years are about 1 inch wider measuring 4.75 inches from mounting bolt to mounting bolt. The bolts themselves are a 1/2—13 coarse thread. The caps had plugs and no zerk fittings installed.

67-69 Cut back vs. Non Cut Back

The original upper control arms that first were introduced in 1967 model year were the C7OZ-3082-A followed by the -B units. These are commonly referred to as the non cutback version as the nose of the control arm (shown below) is not cut. Then with the introduction of the Cobra Jet cars with wider tires about April 1968 the -C version was introduced—also referred to as the cutback version. The area at the nose of the control arm was cut back so that interference or rubbing against the tire would not be an issue.

The cutback version was used into the 1969 model year but at that point Ford realized there was an issue with the cutback versions cracking along the edge that was cut away. Because of this they went back to using the non cutback version. This gives the general timeline of these changes, but they can vary.



The above control arm is a cutback style still mounted on a 1969 Mustang. Here you can see exactly why there was a concern that wheel and tire would rub up against the control arm especially when turning the wheel as clearance is really close. The ball joints were changed at one time which is why they are not riveted and instead they are bolted in place. Bolted would not be correct in concours restoration or judging.



Above: Side by side comparison to show the area that was cut away from the control arms in the front nose area for clearance. Cut back version is laying on top of the non cut back in these three photos.



Cracking Shown here is the cutback version of the control arms (left) where you can see issues with cracks in the metal where it was stressed. This is not uncommon on these version of control arms and exactly why Ford went and changed back to the non cutback version in 1969.

1969 and 1970 Boss 429

The 1969 and 1970 Boss 429 upper control arms were a completely different and separate version of control arm all by themselves. These control arms are based on the C7OZ-3082-A control arm (see previous two pages), with one difference. On the back area of the control arm, at the control arm shaft, it was cut to give more clearance between the modified Boss 429 shock towers and the actual control arm itself. Hard to spot this difference by itself, but the photos here show that change and the difference compared to a regular production control arm. Otherwise they use the same ball joints, boots, rivets and other features. Its typical to have orange sprayed on the nose of the upper control arm to identify them as special Boss 429 only parts.



Above: Picture shows clearance issue with the upper control arm and the shock tower and why Ford engineers wanted the extra area to be cut to give added clearance.

Right: Side by side comparison of a restored Boss 429 control arm and an original normal production Mustang upper control arm.

NAME

ARM - FRONT SUSPENSION - UPPER

NO.

C9ZX - 3082 - A



1970 to 1973 D00Z-3082-A

The last design change during these years came in 1970, with the introduction of the three rivet upper control arm. The nose area, instead of having a 4 rivet ball joint, now has a three rivet ball joint design. This was believed to be more sturdy and at the same time solve clearance issues with larger tires that could rub against the upper control arm. The waffle rivet design is the same as previous years, as are other features (no paint, same control arm shaft kits, etc). Major differences shown below.



Ball joint is a different design than previous years but still has the same tabs that is seen along the edges making this unique and easy to identify as an original Ford ball joint assembly.

Ball joint boots were a D00Z-3A105-A part number with the engineering number of D00A-3A047-A and the word UPPER molded in them. These boots are completely different in design as they no longer require a metal hold down retaining plate as previous years. They are a direct fit pressed fit over the ball joint assembly making it easier to change when ripped or damaged.

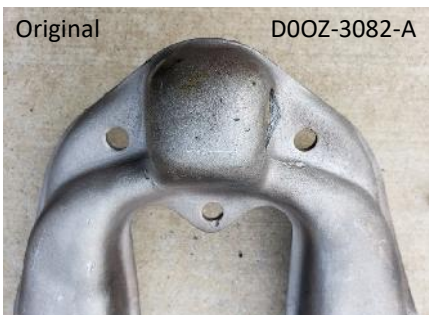

Left: Shown here is a side by side comparison of the original assembly line version D00Z-3082-A control arm vs the later Ford service replacement D50Z-3082-A. Note the front leading edge which was originally rounded was cut flat to give more clearance on the D5 version. Another example of how service parts are not always the same.

Cross Member 1965 to 1970

All Mustangs built from 1965 thru 1970 model year had a lower engine crossmember installed. These were all the same regardless of engine options ordered or specific models. There is two version of these with the first version used in the 1965 and 1966 model year. The second version was from 1967 to 1970 model years.

Although they are completely different, they carry the same part number thru all these years which is a C5ZZ-5026-A. However the engineering numbers did change from a C4ZA-5026-A for the first version to a C7ZA-5026-A for the second version. Difference and details shown below.



Above: Side by side comparison of version A and version B

Right: Both versions have a flat spot that would be on the drivers side that was to help clear power steering lines in that area.

Below Left: The early cross members used in the 1965 and 1966 model years typically have no stampings at all, while the 1967 to 1970 version will have a FoMoCo in the center that is stamped. This stamping is visible when mounted on the car from underneath if it has not been dented or scratched in that area.

Below Right: Original bolts used to hold the cross members in place are tapered as shown and the head marking has a F stamped on it. These would be a phosphate finish. These are different than any reproductions available today.

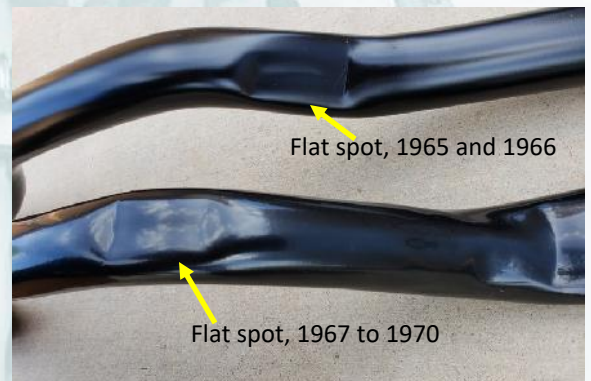

Idler Arms

The idler arm serves as a pivoting support for the steering linkage and is used to hold the center link at the proper height. From 1965 to 1973 the idler arms that Ford designed changed from having several different versions being used in the same model year (depending on steering options), to one version being used from 1971 to 1973 regardless of steering options. Much like some other components covered in this guide, production costs, maintenance, and service were made easier by these changes. This section details the year by year changes and how to identify what is correct per application.

1965 and 1966 Idler Arm Mounting Bracket

For these two years Ford designed the idler arm as two sub-assemblies, with the idler arm and the idler mounting bracket being two distinct parts with two distinct different part numbers. The idler mounting bracket was serviced under the part number of C3DZ-3351-A (shown below). This piece would bolt to the body of the car and be attached to the idler arm with a washer, cotter pin and cotter nut and typically have a green paint dab.



1965 and 1966 Idler Arms

Six cylinder Mustang, with manual steering, C3DZ-3352-L



Marked C4DA-3355-A



Idler Arms cont.

1965 and 1966 six cylinder Mustang, with power steering, C4DZ-3352-B



1965 and 1966 eight cylinder Mustang, with manual steering, C5ZZ-3352-A

Typically identified with a dab of brown paint

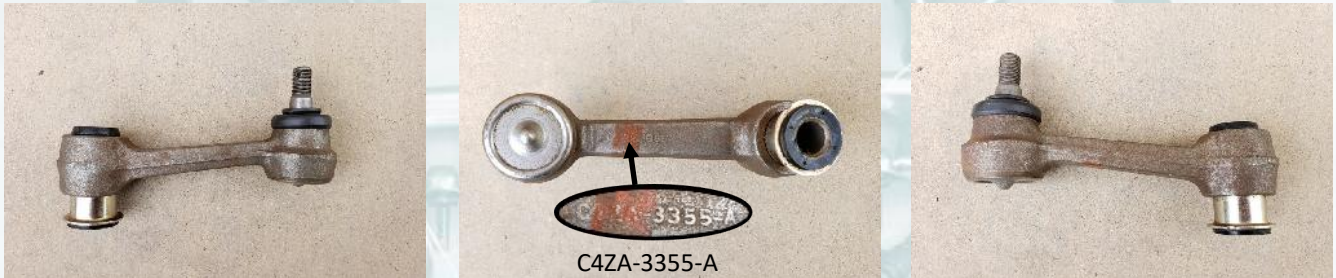

1965 and 1966 eight cylinder Mustang, with power steering, C5ZZ-3352-B

Typically identified with a dab of teal blue paint



1965 and 1966 Idler Arm Dust Boot

All 1965 and 1966 idler arms (except 6 cyl, manual) used a dust boot on the idler arm stud that attached to the center link. The original dust boots are identified with the engineering number of C4ZA-3A196-A.



Idler Arms cont.

1965 and 1966 Shelby Mustang

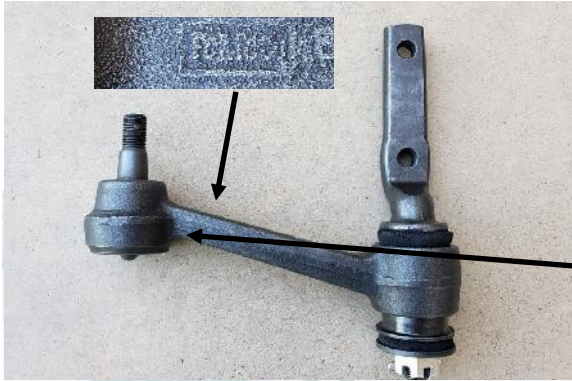

Shown here is a complete and original Shelby idler arm assembly with the arm and bracket pieces together. The arm would typically be marked with the engineering number of XRR-25490 and with a FoMoCo or Ford stamp.



1967 to 1970 Idler Arms



For the 1967 to 1970 model years there were two different idler arms used that now included the bracket and arm as a complete assembly. The C7ZZ-3350-B was for manual steering and the C7ZZ-3350-A was for power steering. The visible difference is in the idler arm bracket that mounts to the frame. An easy way to identify a manual steering idler arm is the three holes in the mounting bracket vs two used for power steering. For the arm itself they both use the same that is marked with the C7ZA-3355-B engineering number.



Starting with the 1967 idler arms Ford no longer used a castle nut and cotter pin to hold the arm and bracket together. Instead they used a locknut and swedged the end to keep it place.



1971 to 1973—ALL



The final version of idler arms used on all Mustangs from 1971 to 1973 was consolidated into one version. Rather than have different versions for power steering and manual steering one single idler arm was for all cars. Engineering number on the idler arm would be a D1ZA-3355-AA



Spring Perches

(Seat and Bushing Assembly—Front Suspension Upper Arm Spring)

There is two basic versions of spring perches that were used from 1965 to 1973 as shown here, with some variations within those two versions. The early version used in 1965 and 1966 had a bushing that was pressed in place, but not crimped on the end (see photos). In addition the 1965/66 versions had a knurled bolt that held the spring perch to the control arm that was a fine thread 3/8-24. 1967 to 1973 version used a coarse thread 3/8-16. Change over date seems to be about November 14, 1966.

1965 and 1966



All early spring perches (C4DZ-3388-A) during these years do not have any Ford or FoMoCo stamping on them. They may have some manufacturer marking on them that typically are M-S or A. Correct finish would be a bare metal with the bushing itself a darker color similar to a phosphate color.

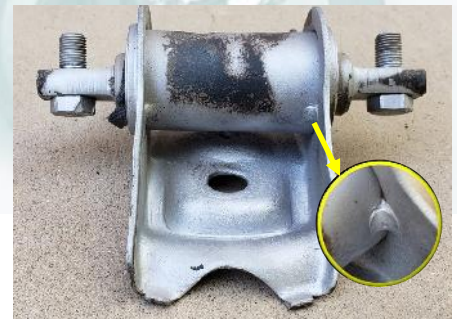

A. Early spring perches in 1964 1/2 and 1965 model year could have the knurled bolts tack welded to the spring perch bushing. In this case the bolt heads would have no markings on them and be phosphate in color.

B. The most common spring perches remain unchanged except for the knurled bolts. The bolts would be zinc or cadmium plated and with two different suppliers, Rockford and a second vendor stamp that was WB.

C. The third and final change was when the bushing was tack welded to the spring perch itself. With the compression of the spring riding on the bushing and spring perch this could cause the bushing to turn loose. That's why the design change in 1967 to crimp the ends.

65/66 Spring Perches cont.



Hardware: Spring perch hardware as shown here includes two different versions of the knurled bolts (Rockford or WB) that hold the perches to the upper control arm, and the hex slotted nuts used to attach. This hardware is usually zinc or cadmium and a 3/8-24 thread.

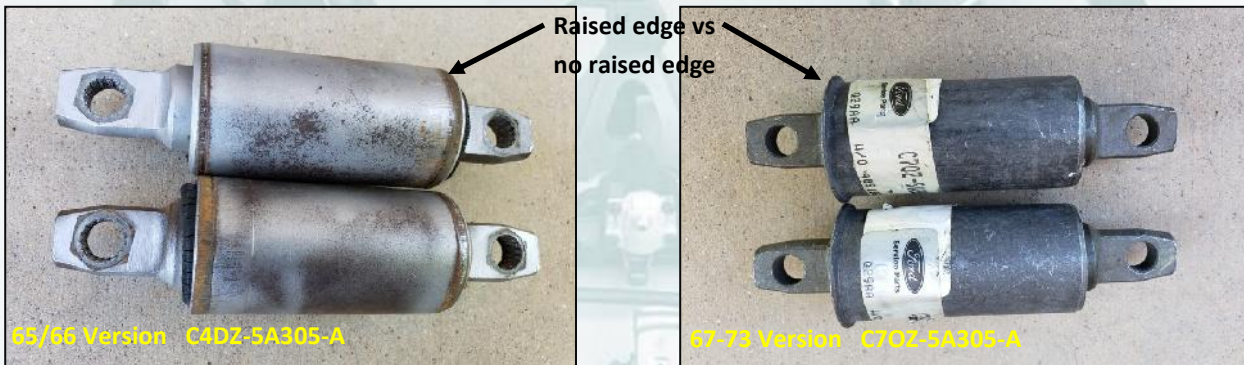

Bushings: The actual spring perch bushings used in 1965 and 1966 are different from the 1967 to 1973 version as shown. These early versions do not have a raised edge like the later versions do.



Paint markings. Original bushings on the spring perches had the rubber marked with yellow on one side to indicate the wider flared part of the bushing to make sure it was installed correctly in the spring perch itself. Shown here from two different perches you can still see the original yellow paint.

Stampings: Early spring perches have no FoMoCo stamping but only a vendor stamping, if any at all. Normally seen as an A or M-S stamp.

1967 to 1973 Spring Perches



The new spring perches for 1967 (C70Z-3388-B) are almost identical to the previous version except the bushing is now crimped in place, the hold down studs are coarse thread, and the FoMoCo stampings now appear on them.



ABOVE: Two styles of knurled bolts and nuts were used as shown. The bolts typically have either a M or N stamping on the head. All hardware would be phosphate finish.

ABOVE: FoMoCo stamps now appear on these spring perches during these years with the block style at first and then changing to the oval. Change over period is approximately 1969.



LEFT: As with previous versions you can find the yellow paint markings on the rubber bushing on the one end as shown here.

67 to 73 Spring Perches cont.



Shown here the most common style of crimping on the end of the spring perch bushing to help keep it in place. Usually we see 4 crimps to hold the bushing in place.



LEFT: Shown here is original Ford spring perch bushings for reference on the correct finish. These are C70Z-5A305-A bushings that were serviced for a number of years.

Special Boss 429 spring perches

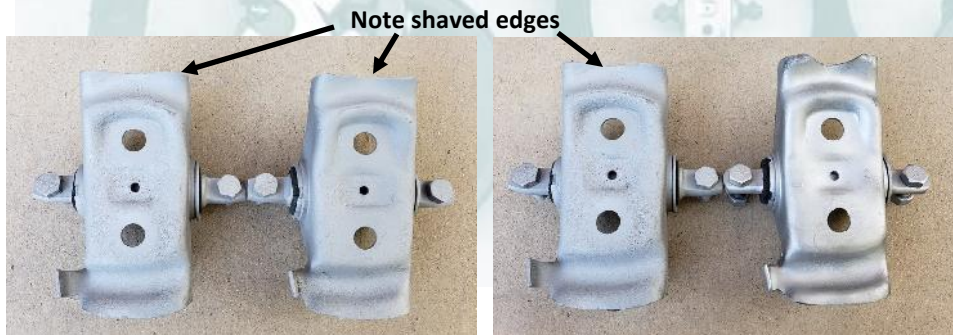

LEFT: All 1969 and 1970 Boss429's had their own unique spring perches under the part number C9ZZ-3388-A. These are like all other spring perches during this time except the one edge was cut away for added clearance.

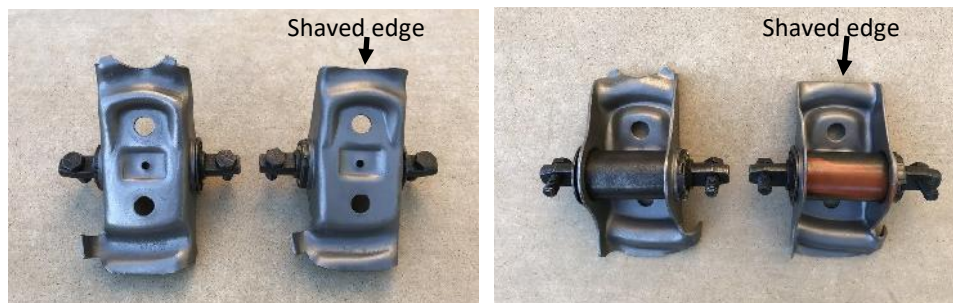

As with many unique Boss429 chassis parts they had an orange paint dab applied. This could vary on how it was applied but generally as shown here on the left.

Later service replacements



D2DZ-3388-A The first generation of replacement spring perches are exactly the same as the C7OZ-3388-B versions that were used since 1967 except for the added rubber pads that are glued to the spring perch where the coil spring would rest. Otherwise they are identical. Typical service pieces are painted black.



C7OZ Version



D7DY Version



D7DY-3388-A The most common service replacement sold over the years from Ford was this version and was available for many years. Very different from the originals these were usually painted black, had no weep hole in the middle of the spring perch and included rubber pads where the springs seat.

Also looking at the side profile the spring stop is much longer in shape than other versions. See photos for side by side comparison.

Steering Boxes

(Gear Assembly—Steering)

Steering boxes that came on the Mustangs and Cougars between 1965 and 1973 came in three basic styles shown below. Within these years, non integral steering boxes were used from 1965 thru 1970. This terminology means that the power steering components are completely separate from the steering boxes and not “integrated”. Then from 1971 to 1973 the steering boxes were referred to integral power steering boxes where the power steering lines were connected to the box (if equipped). The 1965 to 1970 steering boxes are based on a Saginaw design first introduced in the 1950s that by the mid 1960s became an industry standard used by General Motors, Ford, Chrysler and American Motors.

- The first generation referred to the long shaft style (about 42 inches) had an input shaft that extended from the steering wheel thru the column all the way to the steering box. This was used until about early 1967 calendar year where this then this started to transition to a short input shaft. Change was due to the fact that all vehicles would be required by the NHTSA to have a collapsible steering column which was impossible with the long input shaft. And also the tilt wheel steering option introduced in 1967 had to use the short shaft steering box.
- The second generation steering box was used from 1967 calendar year until the end of the 1970 model year. This version of steering box looks the same as first version but with a short input shaft (about 6 inches).
- The third generation used is the larger integral steering boxes that were used for model years 1971-1973 and actually have the power steering lines attached and part of the steering box.

Note: On the first generation steering boxes the fill plug was not vented. This is because the venting was actually thru the top of the box as its not completely sealed. The second generation used a vented fill plug. Photos below:

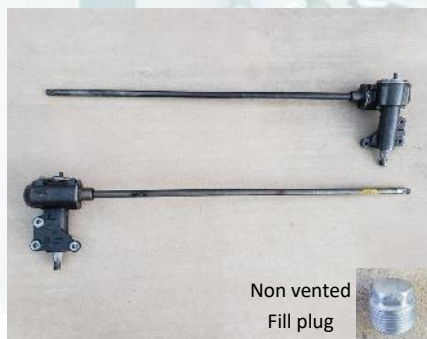

First Generation



Second Generation



Third Generation



Steering boxes—cont.

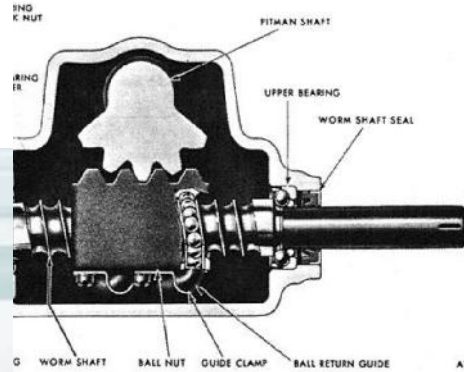
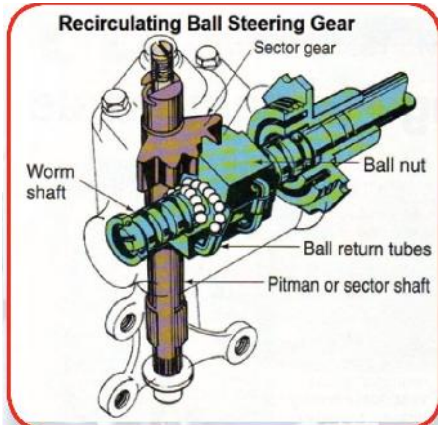

Shown here on the left is the internal workings of the steering boxes used from 1965 to end of model year 1970. These type of boxes were also called recirculating ball steering gears because of the design that shows these going thru the rack block and the worm gear. Simple but effective design these would be filled with moly based grease, and never oil.

Many people do not realize that during the 1960's and 1970's most of the components that were serviced were actually done so at the dealership and not replaced as a complete unit. This is true for steering boxes as each and every part of a steering box was sold and serviced by Ford. Some examples shown here that are all NOS pieces.



Steering ratios on the first and second generation steering boxes (1965 to 1970) actually just came in two different configurations. They were either a 16:1 or a 19:1. The 16:1 is considered a quick ratio because it takes less turns of the steering wheel to go from one full stop to the other versus the 19:1. The 19:1 ratio (slow ratio) is typically on manual steering cars where the 16:1 is typically on power steering, GT, and performance packages. Shown below is what the actual difference is between the two ratios as the number of grooves that is cut into the worm gear. One has 8 grooves (quick ratio) and the other has 10 grooves.

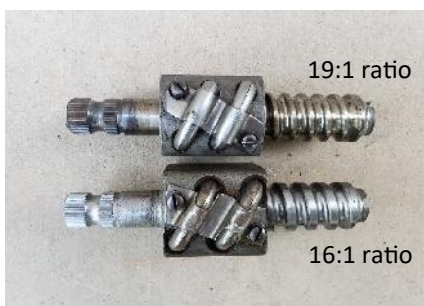

Steering boxes - cont.

Shown on this page and the next is the chart for Mustang and Cougar steering boxes. This does not cover every single type of steering box Ford made as there is others that look similar to a Mustang/Cougar but are actually for different applications. If you do not see your tag listed here it's a good chance its from something else. The tags themselves are useful to help date code cars since its common the original steering box is still on the car and never removed, even in junk yards when everything else has been removed. The steering box itself would have a cast date in the housing and then the assembly date is the tag as shown below. These tags could be as close as a few days apart from the casting date. The steering box tags will have a prefix and suffix that is decoded for the application.

One notable change in the steering boxes in 1967 is the sector shaft diameter changed from 1.000 inch to 1.125 inches. This change happened approximately in May of 1967 to make the shaft less prone to being damaged or broken.



Steering boxes in many cases could have a black out paint brushed on the assembly line to the top of the steering box and cover. Not all of them had this applied, but in many cases it was to help prevent flash rust as would be seen when the hood was open looking down at the steering box.



SMB F - 16:1 ratio

Cast date of the housing 9L20

0A08B - Jan 8, 1970 2nd shift

November 20, 1969



HCC AX - 16:1 ratio

Cast date of the housing 5D9

5D26B - April 26, 1965 2nd shift

April 9, 1965

Year	Manual or Power	Steering Ratio	Sector Diameter	Tag Code	Comments
1965	Manual	19:1	1 inch	HCC-AT	
1965	Power	16:1	1 inch	HCC-AW	
1965	Manual	16:1	1 inch	HCC-AX	Handling Package
1966	Manual	19:1	1 inch	HCC-AT	
1966	Power	16:1	1 inch	HCC-AW	
1966	Manual	16:1	1 inch	HCC-AX	Handling Package

Steering boxes - cont.

Note: Long shaft steering boxes were never installed on Cougars

Year	Manual or Power	Steering Ratio	Sector Diameter	Tag Code	Comments
1967	Manual	19:1	1 inch	SMB A	Long input shaft
1967	Manual	16:1	1 inch	SMB B	Long input shaft
1967	Manual	19:1	1 inch	SMB C	
1967	Manual	19:1	1 1/8 inch	SMB D	
1967	Both	16:1	1 inch	SMB E	Handling Package
1967	Manual	16:1	1 1/8 inch	SMB F	Handling Package
1967	Manual	19:1	1 1/8 inch	SMB H	Long input shaft
1967	Power	16:1	1 1/8 inch	SMB J	Long input shaft
1967	Power	16:1	1 1/8 inch	SMB K	
1968	Manual	19:1	1 1/8 inch	SMB D	
1968	Manual	16:1	1 1/8 inch	SMB F	Handling Package
1968	Power	16:1	1 1/8 inch	SMB K	
1969	Manual	19:1	1 1/8 inch	SMB D	
1969	Manual	16:1	1 1/8 inch	SMB F	Handling Package
1969	Power	16:1	1 1/8 inch	SMB K	
1970	Manual	19:1	1 1/8 inch	SMB D	
1970	Manual	16:1	1 1/8 inch	SMB F	Handling Package
1970	Power	16:1	1 1/8 inch	SMB K	
1971	Manual	22:1		SMA R	
1971	Power	17.5:1		SPA S, U	
1971	Power	16:1 to 13:1		SPA T, V	Variable Ratio
1972	Manual	24:1		SMA T	
1972	Power	17.5:1		SPA S, U	
1972	Power	16:1 to 13:1		SPA T, V	Variable Ratio
1973	Manual	24:1		SMA T	
1973	Power	17.5:1		SPA S, U	
1973	Power	16:1 to 13:1		SPA T, V	Variable Ratio
1973	Power	17.5:1		SPA AC, AE	
1973	Power	16:1 to 13:1		SPA AD, AF	Variable Ratio

Strut Rods

(Strut, Front suspension lower arm)

From the model years 1965 thru 1973 there was five different versions of strut rods Ford designed and used detailed here in this section. The main purpose of a strut rod is to act as a third point to triangulate the lower control arm. This helps during braking and acceleration keeping things in place. They are not plated or painted but have a natural finish on them from the factory.

1965 and 1966 Strut Rods



The 1965 and 1966 body style used the C5ZZ-3468-B strut rods. These are the same for 6 and 8 cylinder with no difference. These strut rods are also completely interchangeable from left and right sides. A natural finish as shown here on this NOS set is how they were originally manufactured but can vary a bit.

The strut rods themselves do have a specific up and down orientation and were marked from the factory with a yellow paint dab on them as shown here to indicate this is the way they were installed facing down. There is also a cast in "slash mark" to show this (refer to photo).

The mounting hardware that connect the strut rod to the lower control arm is shown here. The studs and nuts are a zinc or cadmium finish.

1967 Mustang Strut Rods



1967 Mustang strut rods are a one year only application under the part number C6OZ-3468-A. These do not interchange with any other Mustang or Cougar application. Just like the 1965/66 strut rods the left and right sides are the same. Typical mounting hardware for strut rod to control arms shown here as well.

1967 Cougar Strut Rods

The 1967 Mercury Cougars had a one year only design on the strut rods. The strut rods themselves are interchangeable from left and right sides and come under the part number C7WY-1111-C. Pictures here show this unique design with the special attaching hardware that mounts to the lower control arm.



1968 and 1969 Strut Rods (Excluding Boss)



All 1968 and 1969 Mustang and Cougars used the same strut rods excluding Boss (see below). Right hand is a C8OZ-3468-A and the left is a C8OZ-3468-B. The ends have a stepped down machined area where a castle nut and cotter pin are installed. 1968 and early 1969 production use a fine thread set of hardware after which a coarse thread version was used all the way thru end of 1973. See photos next page how they were installed.

1969 Boss



The 1969 Boss cars came with this variant of the strut rods. It has the stepped down ends with the castle nut and the cotter pin but also has the heavier reinforced flange area that bolts to the lower control arm. The right side is a C9ZZ-3468-A and the left side is a C9ZZ-3468-B. Photo on left shows the difference in the flanged area when compared to a standard 68/69 strut rod.

1970 to 1973 Strut Rods



The final version of strut rods shown here is the 1970 to 1973 version. This version no longer uses the stepped down machined front of the strut rod with a castle nut and cotter pin. Otherwise mounting hardware to the lower control arm is the same as previous years. Part number is a C9ZZ-3468-C for the right hand and a C9ZZ-3468-D for the left hand and this became a service replacement as the -A and -B versions were no longer available.

Original unrestored installation photos

Pictures here show typical installation of the lower control arms on two unrestored low mileage cars. The strut rods on a 1969 Boss 429 (left) and a 1968 Mustang (right side photo). Notice the cotter pins and how they are installed and the hardware.



Tie Rods

(Front wheel spindle connecting rod or end)

The tie rod assemblies from 1965 to 1973 have two basic variations during these years. The one common point with all of them, that makes them easy to identify, is they never had a zerk fitting (grease fitting). If there is a tie rod with a zerk fitting it is an aftermarket replacement, as even the service replacements Ford sold never had zerk fittings for these years.

The tie rod design was a “sealed” assembly that came in two basic versions. The first generation of tie rods used during these years was for the 1965 and 1966 model years. These tie rods were sealed and had a small amount of grease from initial assembly inside. However they were prone to getting contamination inside if the boot was ripped or torn and then would deteriorate. Because of this Ford changed the design which was then used from 1967 to 1973. This version was self lubricating in the sense that the ball stud was sealed inside plastic that worked to keep things free and moving. This type of design principle is still used today on modern vehicles and preferred in many ways over the style that requires grease because it keeps contamination and dirt from getting inside and from the boots being ripped apart from too much grease being added. A quick visual of what the tie rods look like is shown below.

Tie rod boots are also easy to identify and narrow down. The original tie rod boots from 1965 to 1970 had a zinc or cadmium plated metal ring on the outside edge that can be seen when installed. This design was used until 1969 model year and then changed in 1970 when this visual feature was no longer present. Tie rod boots that do not have this metal ring before 1970 would not be considered assembly line original.

Anatomy of a tie rod



1965 and 1966 Pictures here to the left show the tie rod internals. The threaded ball stud is pressed against a spring and a small amount of grease and held with a cap. This design is much more prone to getting dirt inside causing premature failure.

1967 to 1973 Pictures here to the right show the internals of the tie rod which has the threaded ball stud encased in a plastic mold. This would then be pressed in place and held with a cap.



Tie Rods 1965—1966

Six cylinder Mustang, with manual steering

The simplest and most basic of all tie rod combinations. The inner and outer tie rods are essentially the same with the only difference being the threaded ends. One tie rod has left hand threads, and the other has right hand threads.



Inner tie rods are a C3DZ-3A130-L and the outer tie rods are a C3DZ-3A130-K. The ball stud uses a 3/8-24 castle nut and the tie rod boot has the metal ring as shown visible. The end cap detail shown above with no visible stampings on the end cap. The original tie rod boot (C3DZ-3332-A) does not have any engineering numbers, but do have a mold number, mold cavity number and a source identification number.

Tie rod sleeves (C5ZZ-3310-A) are a 1/2-20 thread with left hand thread on one side and right hand thread on the other side. The left handed thread side is marked with a small hole that is drilled in the sleeve for identification. Overall length of the sleeve is 5 7/8 inches. The clamps are held in place with bolts that have a fine thread 5/16-24 and with shoulder nuts. Most common head markings as shown being an A or a RSC.

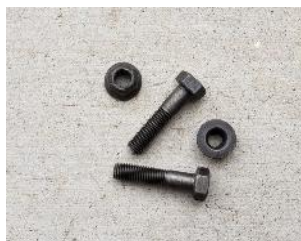

Tie Rods 1965—1966 cont.

Six cylinder Mustang, with power steering

The six cylinder Mustang, with power steering, is probably the most unusual as it was the least ordered of all the combinations. Very few cars were ordered this way. With this configuration there is four unique tie rods with four unique part numbers as the tie rods as they are not interchangeable between left and right.

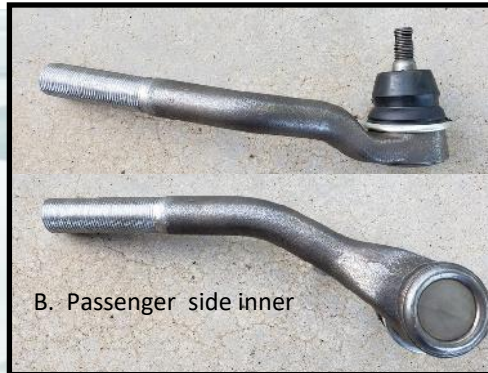
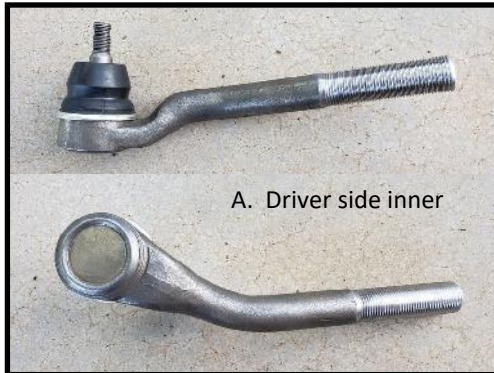

Part Numbers:

- A. C4DZ-3A131-C
- B. C4DZ-3A130-D
- C. C4DZ-3A131-D
- D. C4DZ-3A130-C



Tie rod boots are C3DZ-3332-A with no engineering numbers. Just mold numbers, mold cavity number and supplier ID.



Tie rod sleeves (C2AA-3310-B) are a 11/16-18 thread. The left handed thread is marked with a small indent for identification. Overall length of the sleeve is 4 1/2 inches. Two different style of clamps were made and either could have been used. Clamps are held in place with bolts that have a fine thread 5/16-24. Most common head markings being an A or a RSC.



Tie Rods 1965—1966 cont.

Eight cylinder Mustang, with manual steering

As with the 6 cylinder Mustang configuration, the 8 cylinder manual steering configuration is the simplest. There is an outer tie rod which is not specific for left and right sides and an inner tie rod that is not specific for left and right sides.

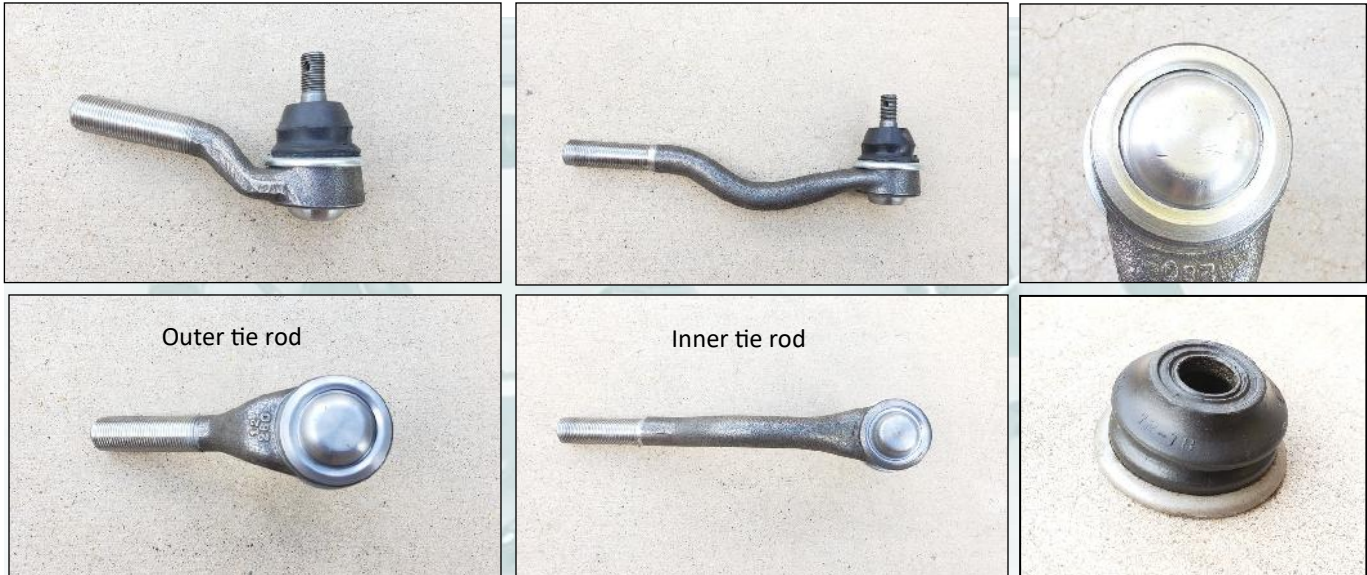

Inner tie rods are a C5ZZ-3A131-D and the outer tie rods are a C5ZZ-3A130-D. The ball stud uses a 7/16-20 castle nut and the tie rod boot has the metal ring as shown visible. The end cap has no visible stampings on the end cap itself. The original tie rod boot (C5ZZ- 3332-A) does not have any engineering numbers, but does have a mold number, mold cavity number and a source identification number.

Tie rod sleeves (C2AA-3310-B) are a 11/16-18 thread with left hand thread on one side and right hand thread on the other side. The left handed thread side is marked with a small indent on the sleeve for identification. Overall length of the sleeve is 4 1/2 inches. The clamps are held in place with bolts that have a fine thread 5/16-24 with the most common head markings being a TR (Towne Robinson Nut Company).



Tie Rods 1965—1966 cont.

Eight cylinder Mustang, with power steering

The eight cylinder Mustang, with power steering, is the same as the eight cylinder Mustang with manual steering on the passenger side. The difference comes on the driver side where there is two unique tie rods which are designed so there is enough clearance with the power steering components and therefore different part numbers.

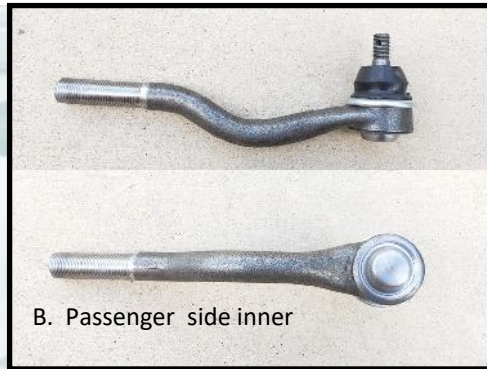
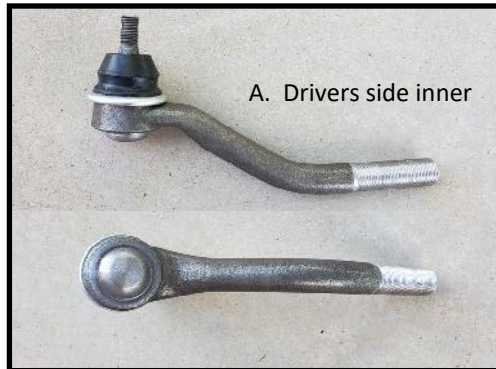

Part Numbers:

- A. C5ZZ-3A131-C
- B. C5ZZ-3A131-D
- C. C5ZZ-3A130-C
- D. C5ZZ-3A130-D



Tie rod boots are C5ZZ-3332-A with no engineering numbers. Just mold numbers, mold cavity number and supplier ID.



In this application there is actually two different tie rod sleeves used because the size of the threaded ends of the tie rods are larger on the drivers side. Because of this the drivers side sleeve uses a C2VY-3310-A and the passenger side uses a C2AA-3310-B. The tie rod caps do not have any markings. Other features of this tie rod set are shown in photos below.



Tie Rods 1967—1969

Starting in the 1967 model year, Ford simplified the suspension design and only had an inner and an outer tie rod that were unique and there was no longer differences for 6 and 8 cylinder models and no differences for manual and power steering like the previous years. The cap design on the end of the tie rod changed as well, with the most common instance having a B stamped in the center, although not all examples have that. Some may have no stamp. Inner tie rods are a C7ZZ-3A131-A and the outer tie rods are a C7ZZ-3A130-A. The tie rod ball stud uses a 7/16-20 castle nut. The tie rod boots used in 1967 have an engineering number of C60A-3332-A and come in both a large and small print. The tie rod boots used in 1968 and 1969 have

an engineering number of C80A-3332-A and also come in a large and small print. The difference in print is only related to vendor and not related to time frame as there were two major suppliers of the tie rod boots during this time designated by a GS or EP stamp on the boot.



The tie rod adjusting sleeve is a C2AA-3310-B with an 11/16-18 thread. The clamps totally change from previous years and are now a B7A-3287-A and look completely different. Bolts have a 5/16-24 thread during 1967 and 1968 and change to a 5/16-18 coarse thread in 1969. There were two suppliers of the bolts; Ajax Bolt and Screw Co (A) and Republic Steel Corporation (RSC). The fine thread bolts have two different versions of locking nuts that are used, but when the switch is done to the coarse thread only one style of locking nut is used.



Fine thread 1967 and 1968 hardware



Coarse Thread 1969 hardware

1969 Boss 302 and Boss 429, 1969 and 1970 Shelby

Ford re-designed the tie rod assemblies as part of the release of the "larger suspension" cars that were being produced in 1969 that included the Boss302, Boss 429 and the 1969 Shelby's (for Shelby's these "larger suspension" tie rods only started being used around March/April 1969). These were originally a DODZ-3A131-A on the inner tie rods and a DODZ-3A130-A on the outer tie rods. These tie rods were serviced by Ford for only a short time before they were replaced by the more common 1970 version (see following page). The main difference on this style of tie rod is that the tie rod ball stud diameter increased



from a 7/16-20 that was used in the 1967-1969 version (previous page) to the larger 1/2-20 that is now used here. See pictures below showing the side by side comparison. Tie rod end cap would normally have a B stamped in the center as shown.



These tie rods used special tie rod boots that were made specifically for this application under engineering number DODA-3332-A that is also molded into the rubber boot. Because of the limited quantities that needed to be made (versus normal production Mustangs and other cars) only one vendor of boot is seen and therefore only one style of lettering. The tie rod sleeve and clamps and bolts are shown below with coarse thread bolts and marked with an A (Ajax Bolt and Screw Co) or RSC (Republic Steel Corporation).



Tie Rods 1970

In 1970 Ford again changed the design of the tie rod assemblies. The tie rods now have a larger style tie rod ball stud that had a 1/2-20 threaded end. The inner tie rods are a D0ZZ-3A131-B and the outer tie rods are a D00Z-3A130-B. There is now a new version of tie rod boot that no longer has a visible metal ring around the base. The tie rod boot has an engineering number of D00A-3332-C molded in the boot and come in both a large and small print with the difference being two different vendors supplying the boots.



The tie rod adjusting sleeve is a C2AA-3310-B with an 11/16-18 thread. The clamps are a B7A-3287-A. Bolts have a 5/16-20 coarse thread design. There were two suppliers of the bolts; Ajax Bolt and Screw Co (A) and Republic Steel Corporation (RSC). The bolts are held in place with a locking style nut as shown in the photos with two versions of locking nuts being used from two different sources.



Tie Rods 1971 –1973

Tie rods from 1971 to 1973 are almost exactly the same as the 1970 design, except the inner tie rod design is now changed. The tie rods still have the larger style tie rod ball stud that had a 1/2-20 threaded end. The inner tie rods are a D1ZZ-3A131-A and the outer tie rods are a D00Z-3A130-B. The tie rod boot has an engineering number of D00A-3332-C molded in the boot and come in both a large and small print with the difference being two different vendors supplying the boots.



The tie rod adjusting sleeve is a C2AA-3310-B with an 11/16-18 thread. The clamps are a B7A-3287-A. Bolts have a 5/16-20 coarse thread design. There were three suppliers of the bolts; Ajax Bolt and Screw Co (A), Cold Heading Company (CH), and Republic Steel Corporation (RSC). The bolts are held in place with a locking style nut as shown in the photos with two versions of locking nuts being used from two different sources.

